

# Fiber-Fiber™ 1xN Series Fiber Optical Switch

(all fiber type, ultra-broadband, Bidirectional, 20W power handling)



(Protected by U.S. patents 6823102 pending patents)

DATASHEET

BUY NOW



## Applications

- Optical Signal Routing
- Network Protection
- Wavelength Management
- Signal Monitoring
- Instrumentation

## Features

- Low Cost
- High Reliability
- Low Insertion Loss
- Broad Band
- Compact Design
- Low Power Switching

The Fiber-Fiber™ 1xN series Broadband Fiber Optical Switch connects optical channels using a patent-pending v-groove technology activated via an electrical control signal. The switch is a cost effective solution for sensor and spectroscopy applications. The unique design has no optical coating, offering low insertion loss and broad spectral band operation from 200 to 2000 nm with high power handling. MWIR and LWIR versions are also available. It accommodates all types of fibers including single mode and multimode with fiber core size from 50 to 1000  $\mu\text{m}$ . The switch is bidirectional and has a large number of ports up to 300 fibers. We have verified the switch high reliability with continuous operation for several years.

The switch is controlled by RS232 or USB computer interface with a graphic Software. Labview version is also available. A fully packaged box module is available.

Lightpath in the device is bidirectional.

## Specifications

Parameter		Min	Typica	Max	Unit
Operation Wavelength	UV-VIS	200		2000	nm
	MWIR	1000		5000	
	LWIR	7000		12000	
Insertion Loss <sup>[1]</sup>			0.3	1	dB
Port Uniformity			0.3	0.6	dB
Wavelength Dependence Loss			0.15	0.2	dB
Polarization Dependent Loss			0.05	0.1	dB
Cross Talk		50	60		dB
Return Loss <sup>[2]</sup>	APC	50			dB
	UPC	40			
Switch Time				200	ms
Switch type			Latching		
Durability		10 <sup>7</sup>			cycle
Optical Power Handling <sup>[3]</sup>			0.3		W
Operating Temperature		-5		65	°C
Storage Temperature		-40		85	°C
Fiber Type	Single Mode	Corning SMF-28 or equivalent			
	Multimode	50		1000	$\mu\text{m}$

### Notes:

[1]. Measured without connectors for 1xN. For multimode fiber, use a laser source with CPR<15

[2]. For SM. Larger core will reduce the value. High return index matching version is available

[3]. High power version is available

**Legal notices:** All product information is believed to be accurate and is subject to change without notice. Information contained herein shall legally bind Agiltron only if it is specifically incorporated into the terms and conditions of a sales agreement. Some specific combinations of options may not be available. The user assumes all risks and liability whatsoever in connection with the use of a product or its application.

Rev 05/08/24

# Fiber-Fiber™ 1xN Series Fiber Optic Switch

(all fiber type, ultra-broadband, Bidirectional, 20W power handling)



## DATASHEET

### Electronic Control Requirements

The sub-module comes with a computer control kit with USB interfaces and Windows™ GUI. It has a wall plug-in power supplier

Parameters	Min	Typical	Max	Unit
Operating Voltage		12	13	VDC
Operating Current	100		200	mA
Power Consumption		3.6	5	W

For USB controlled version, the switch will use the RS232 port and a RS232 to USB converter cable



### Mechanical Dimensions (mm)

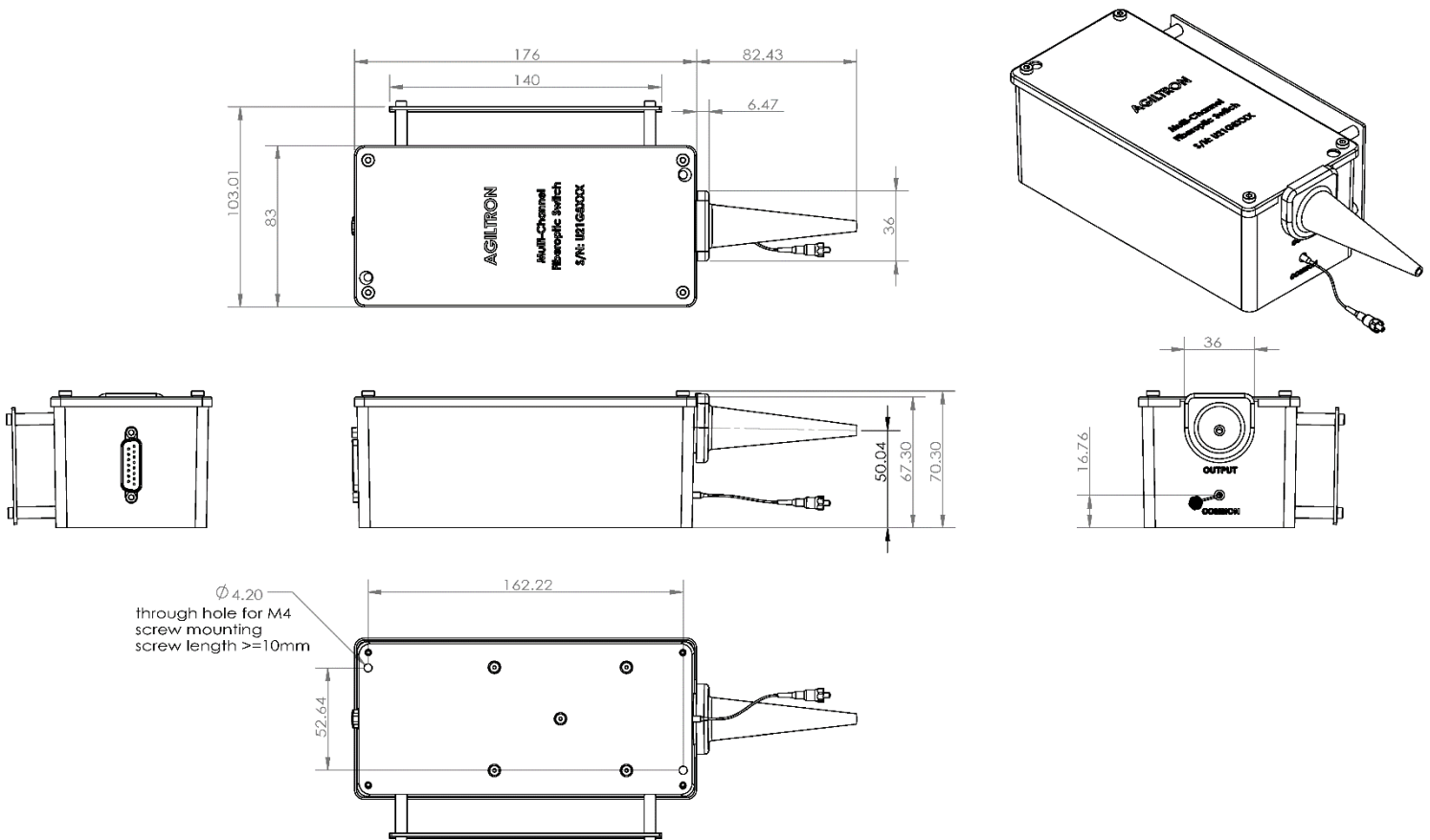

\*Product dimensions may change without notice. This is sometimes required for non-standard specifications.

# Fiber-Fiber™ 1xN Series Fiber Optic Switch



(all fiber type, ultra-broadband, Bidirectional, 20W power handling)

## DATASHEET

### Function Diagram

**SelfAlign 1xN Series Switch**

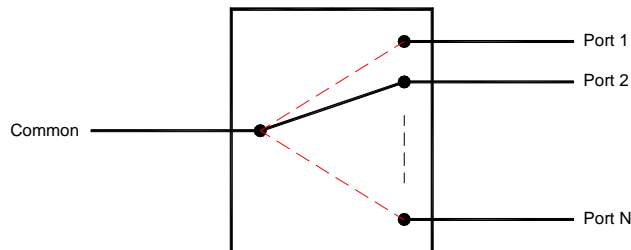

**SelfAlign Dual 1xN Series Switch**

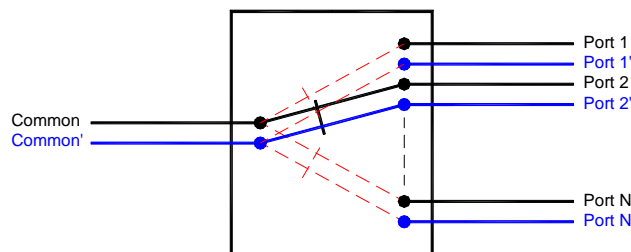

### Ordering Information

Prefix	Type	Wavelength	Configuration	Package	Fiber Type	Fiber Cover	Fiber Length	Connector
<b>LBSA-</b>	1x8 Switch = 008 1x9 Switch = 009 1x10 Switch = 010 ... 1x128 Switch = 128	1060 = 1 1310 = 3 1550 = 5 650 = 6 780 = 7 850 = 8 1310/1550 = 9 350 = A 450 = B 520 = C Special = 0	Single = S Dual = D Special = 0	Standard = 1 Special = 0	50/125 = 5 62.5/125 = 6 105/125 = E 200/NA.22 = F 300/NA.22 = G 400/NA.22 = H 600/NA.22 = J 800/NA.22 = K SM28 <sup>[1]</sup> = S SM1900 <sup>[2]</sup> = M Special = 0	Bare fiber = 1 2 mm Jacket = 2 900µm loose tube = 3 Special = 0	0.25m = 1 0.5m = 2 1.0m = 3 Special = 0	None = 1 FC/PC = 2 FC/APC = 3 SC/PC = 4 SC/APC = 5 ST/PC = 6 LC/PC = 7 Duplex LC/PC = 8 LC/APC = A LC/UPC = U Special = 0

[1]. It uses 1mm collimators covering 1230-1630nm

[2]. It uses 1mm collimators covering 1700-2400nm

RED is Special Order

# Fiber-Fiber™ 1xN Series Fiber Optic Switch

(all fiber type, ultra-broadband, Bidirectional, 20W power handling)



DATASHEET

## Typical Fiber Transmissions

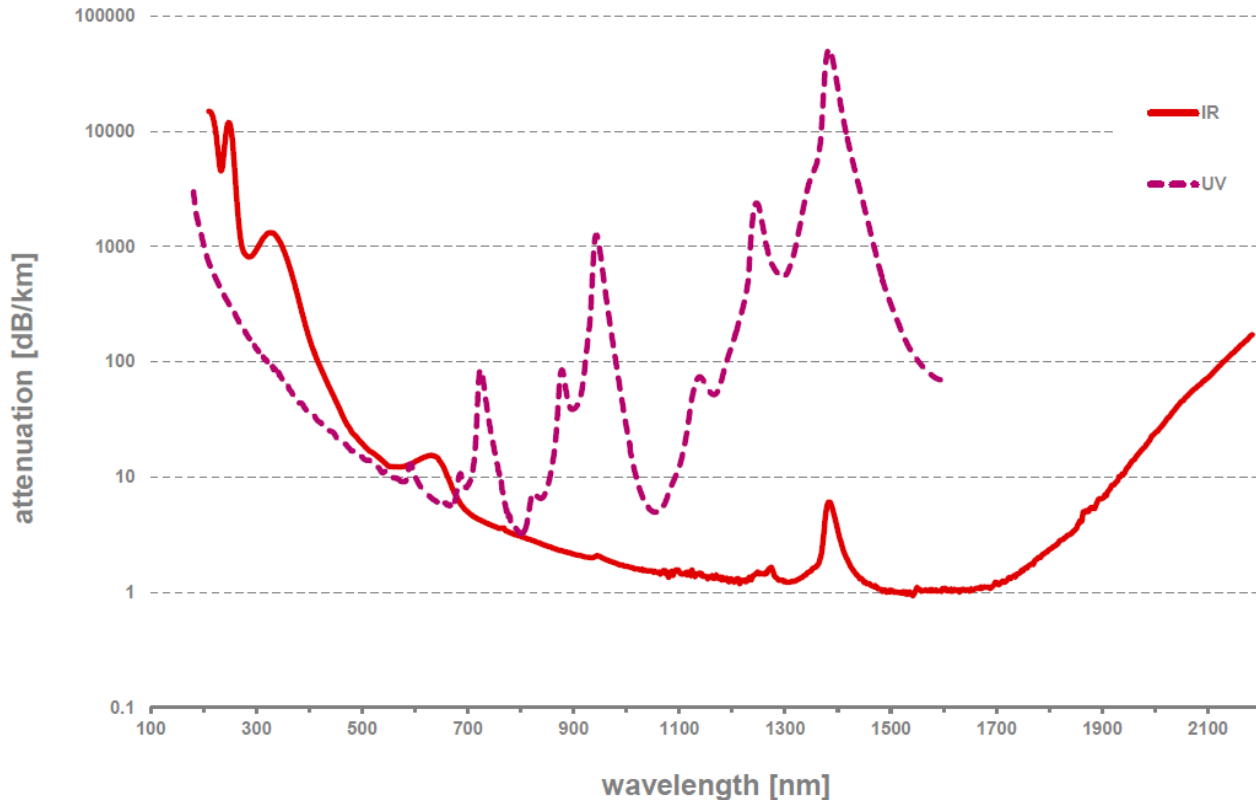

## Application Notes

### Fiber Core Alignment

Note that the minimum attenuation for these devices depends on excellent core-to-core alignment when the connectors are mated. This is crucial for shorter wavelengths with smaller fiber core diameters that can increase the loss of many decibels above the specification if they are not perfectly aligned. Different vendors' connectors may not mate well with each other, especially for angled APC.

### Fiber Cleanliness

Fibers with smaller core diameters ( $< 5 \mu\text{m}$ ) must be kept extremely clean, contamination at fiber-fiber interfaces, combined with the high optical power density, can lead to significant optical damage. This type of damage usually requires re-polishing or replacement of the connector.

### Maximum Optical Input Power

Due to their small fiber core diameters for short wavelength and high photon energies, the damage thresholds for device is substantially reduced than the common 1550nm fiber. To avoid damage to the exposed fiber end faces and internal components, the optical input power should never exceed 20 mW for wavelengths shorter 650nm. We produce a special version to increase the handling by expanding the core side at the fiber ends.